



ELSEVIER

Journal of Chromatography A, 824 (1998) 1–5

JOURNAL OF
CHROMATOGRAPHY A

Detector cell based on plastic liquid-core waveguides suitable for aqueous solutions: one-to-two decades improved detection limits in conventional-size column liquid chromatography with absorption detection

Cees Gooijer*, Gerard Ph. Hoornweg, Tjipke de Beer, Arjen Bader, Dick J. van Iperen, Udo A.Th. Brinkman

Free University, Department of Analytical Chemistry, De Boelelaan 1083, 1081 HV Amsterdam, The Netherlands

Received 21 July 1998; received in revised form 14 August 1998; accepted 14 August 1998

Abstract

A new type of detector cell is presented, which is designed to improve concentration detection limits in conventional-size reversed-phase column liquid chromatography (LC) with ultraviolet (UV)–visible absorption detection. It is based on a recently developed plastic liquid-core waveguide (LCW), suitable for light guidance through aqueous solutions since the refractive index of the plastic perfluorinated polymeric material (denoted as Teflon AF2400) is 1.29, i.e., smaller than that of water (1.33). An LCW of 90 cm length (280 μm I.D.) was brought into a standard UV–Vis absorption detector and a 1.0 m long quartz optical fibre was installed in the reference channel. This LCW detector cell combines an optical pathlength of about 90 cm with an internal volume of 55 μl . An LC separation of three test analytes – the pesticides atrazine, diuron and linuron, which were detected at 250 nm – provided detection limits of 0.3–0.5 $\mu\text{g/l}$. This is 30- to 50-fold better than obtained with the standard detector cell. The linear range extended up to about 1 mg/l. As an application 1 ml of tap water spiked with the test analytes at the 0.2 $\mu\text{g/l}$ level was analysed; the results indicated that such a volume is sufficient to reach the 0.1 $\mu\text{g/l}$ threshold value of the European Union directive without using analyte preconcentration. © 1998 Elsevier Science B.V. All rights reserved.

Keywords: Detection, LC; Liquid-core waveguide detection; Pesticides

1. Introduction

Column liquid chromatography (LC) and, especially, reversed-phase LC is a mature separation technique, which is used in many analytical laboratories, generally in the conventional-size mode with columns of 3.0 or 4.6 mm I.D. It is often combined with absorbance detection in the ultra-

violet and visible (UV–Vis) region of the electromagnetic spectrum, a technique appropriate for all analytes exhibiting moderately to strong molar absorptivity at wavelengths of over about 210 nm. UV–Vis absorbance is the detection technique of choice if quantitative analysis is the main aim. In addition, LC combined with diode array detection (DAD) is widely applied for provisional analyte recognition, even though the identification potential of UV–Vis absorbance is limited because molecular

*Corresponding author.

absorption spectra of liquid solutions do not show much detail.

Unfortunately, the relatively low sensitivity of absorption detection prevents the direct application of LC–UV–Vis absorption to trace analysis as encountered in, for instance, environmental analysis, where analyte concentrations are typically at the low- or sub- $\mu\text{g}/\text{l}$ level. In fact, there is only one instrumental sensitivity parameter in absorption detection, the optical pathlength, which is limited by the chromatographic constraints: to prevent deterioration of the resolution in conventional-size LC, the cell volume should not exceed 10 μl . This implies that in practice the pathlength is 10 mm. In order to deal with the problem of analyte detectability, pre-column derivatization and post-column reaction detection have been developed and spectroscopic detection techniques such as fluorescence and chemiluminescence have been used. More importantly, on-line trace-enrichment procedures based on solid-phase extraction have been designed. In many instances, these are used successfully for 10- to 100-ml aqueous samples which are analysed in fully integrated and automated set-ups [1,2].

In principle, optical pathlengths can be readily increased by using light-guiding capillary cells, usually denoted as liquid-core waveguides (LCWs). Just like optical fibres, LCWs exhibit light guiding under the prerequisite that the refractive index of the core (i.e., the liquid) is higher than that of the cladding, so that total internal reflection occurs. Until recently, it was not possible to meet this requirement for the solvents generally used in reversed-phase LC such as water and methanol which show refractive indices as low as 1.333 and 1.329, respectively, at 20°C, whereas silica-based glasses have refractive indices larger than 1.46 [3]. This explains why, so far, the usefulness of LCWs could be demonstrated only by using high-refractive-index liquids such as aromatics, carbon disulphide and various halogenated compounds [4]. In order to extend the applicability of LCWs to other liquids, including aqueous solutions, metal-coated tubes have been developed and even uncoated borosilicate-glass or fused-silica tubes have been used [5]. With the latter types the protective layer is removed so that the light is guided by total reflection to the outer glass–air, rather than the liquid–glass, boundary. Interesting

results have been obtained for this type of LCWs but, unfortunately, such unprotected capillaries have evident disadvantages. Their light-loss characteristics are determined largely by the quality and condition of their outer surface, they must be cleaned carefully prior to use, and kept clean and handled carefully to avoid scratching; furthermore, they are difficult to bend and quite fragile. As a consequence, they have received little attention in analytical practice.

The present paper focuses on the use of recently developed and commercialized plastic LCWs which are based on a perfluorinated polymeric material with a refractive index lower than that of water, i.e., $n_D = 1.29$ [3,5,6]. Such LCWs do not have any of the disadvantages of uncoated glass tubes. To our best knowledge, this is the first time that such LCWs are used in a conventional UV–Vis absorption detector for conventional-size LC.

2. Experimental

2.1. LC system

The LC system consisted of a laboratory-made six-port injection valve with a 50- μl or a 1-ml injection loop, an LKB Model 2150 pump (Pharmacia, Uppsala, Sweden), a 5 μm C₁₈-bonded silica column (15 cm \times 4.6 mm I.D.) and a Kratos (Ramsey, NJ, USA) Spectroflow 757 UV–Vis absorption detector operated at 2 s rise time. The chromatograms were registered both on a Mode BD40 strip-chart recorder (Kipp, Delft, Netherlands) and an Apple (Cupertino, CA, USA) Macintosh Plus computer via a laboratory-made A/D converter (acquisition rate, 10 Hz; 16 bits resolution). The eluent was methanol–aqueous phosphate buffer (60:40, v/v). The 10 mM buffer solution was prepared by dissolving equal amounts of phosphoric acid and sodium dihydrogenphosphate in quartz-distilled demineralized water and adjusting the pH to 3.0 with concentrated sodium hydroxide solution. The eluent was filtered (0.45 μm) and sonicated at reduced pressure before use; the eluent flow was 1.0 ml/min.

2.2. Chemicals

The solvents were of “HPLC-grade”, and were

obtained from Baker (Deventer, Netherlands). Sodium dihydrogenphosphate and phosphoric acid were also from Baker. Atrazine, diuron and linuron were available from stock [2,3]; they were all at least 95% pure. Sodium hydroxide was obtained from Riedel-de Haën (Seelze, Germany).

2.3. Detection system

The LCW used in this study was purchased from Ocean Optics (Dunedin, FL, USA). It consists of Teflon AF 2400 (code, LPC-1) and has outer and inner diameters of 530 μm O.D. and 280 μm I.D. Both ends of the LCW were glued to a standard (Valco) chromatographic fingertight made of polyethylene terephthalate (PETP). After removal of the cell assembly and bringing the photodiode compartment at a distance of about 1 m from the lamp compartment (while extending the electronic connecting cables) the LCW was installed in the Kratos 757 detector. As shown in Fig. 1, interfacing of the LCW with the lamp and photodiode compartments was achieved by using two laboratory-made PETP termination heads that can be readily clamped. In each of these, holes were drilled, partly provided with a Valco thread. The intersection of the holes form a tiny eluent chamber which was sealed with a quartz window. The effective length of the LCW in this set-up was 90 cm; the detector cell volume, consequently, was 55 μl .

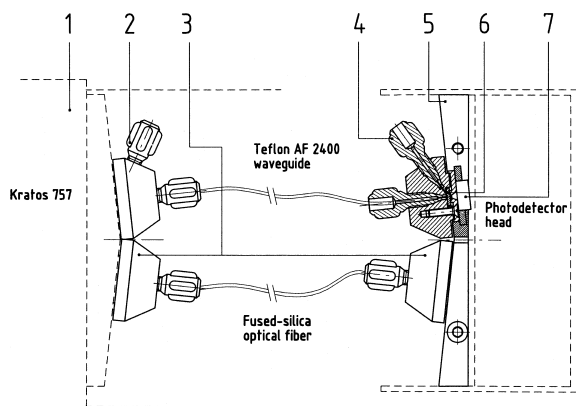

Fig. 1. Detailed picture of the LCW detection system. 1, Lamp compartment; 2, inlet fingertight; 3, termination heads; 4, outlet fingertight; 5, clamp unit; 6, eluent chamber sealed with quartz windows; 7, photodiode.

In a similar way a 1.0 m long polyimide-coated quartz optical fibre (385 μm I.D. \times 415 μm O.D.) purchased from Ensign Bickford Optics (Avon, CN, USA) was installed in the reference channel of the detector. This was used to maintain the “auto zero” option of the instrument for zeroing the baseline.

3. Results and discussion

3.1. Characteristics of the LCW detector

The main goal of the present exploratory study is to show the sensitivity enhancement and the consequent improvement of analyte detectability in (reversed-phase) LC by using LCWs instead of conventional detector cells. Emphasis is not on optimizing the chromatographic conditions and only isocratic separations are considered. In addition, it will be obvious that the 55- μl volume of the 90-cm long LCW with its I.D. of 280 μm (the only waveguide I.D. available to us) certainly is too large or, in other words, extra-column band broadening will not be fully negligible. Although the situation can, in principle, be improved easily by reducing the length of the LCW to, e.g., 30 cm, in this preliminary study we preferred to use the total length of the LCW and, hopefully, maximize the detectability.

A major point to be addressed with regard to LCWs is to study whether they behave as ideal light guides or cause (serious) loss of light. For a first, qualitative comparison, various liquids with strongly different refractive indices, a He–Ne laser (emitting at 632.8 nm) and a power meter were used. It was found that the light attenuation is strongly influenced by the rinsing procedure applied. Whereas without cleaning the light throughput observed for water ($n_D=1.33$) was about six-times lower than that observed for toluene ($n_D=1.48$), no significant difference was observed after rinsing the capillary (with, consecutively, 1 ml of water, methanol, toluene, methanol and water). In fact, after rinsing the throughput was better than 90% for both methanol and water. This is quite high in view of the reflectivity losses at the quartz windows. No exact data can be given at this stage; these will require more sophisticated experiments since additional attenuation due to the input and output coupling of the

LCW to the laser and the power meter have to be taken into account.

For practical reasons, we did not perform detailed light throughput measurements as a function of wavelength, although it should be realized that refractive indices (of both solvents and cladding) decrease with decreasing wavelength and the total reflection efficiency in LCWs may therefore be influenced as well. Instead, the detector was simply set at 250 nm, a suitable wavelength for the detection of many organic microcontaminants which have to be determined in surface and drinking water.

In absorbance measurements a reference channel is required next to the “analyte channel”. This was achieved by installing a 1.0 m fused-silica optical fibre as depicted in Fig. 1. Throughput differences between the LCW (filled with eluent) and the optical fibre could be readily compensated by utilizing the “zero baseline adjustment” of the detector.

3.2. Chromatographic results

The performance of the new LCW detector is illustrated in Fig. 2, which shows the isocratic LC chromatogram obtained for a standard mixture of 1 $\mu\text{g}/\text{l}$ of atrazine, diuron and linuron (dissolved in eluent, 50 μl injected). Comparison of the chromatograms obtained with LCW detection and with the same Kratos instrument (and LC system), but with the standard detector cell (volume, 12 μl ; pathlength, 8 mm) installed, clearly shows that similar sensitivity is obtained for spiking levels of 1 $\mu\text{g}/\text{l}$ and 50 $\mu\text{g}/\text{l}$, respectively. The sensitivity gain is seen to be 30- to 40-fold, which is only two- to three-fold less than can be expected on the basis of the optical path-lengths only, that is, if there would be no additional band broadening. The LCW chromatogram shows that the detection limits for all three test analytes are on the order of 0.3–0.5 $\mu\text{g}/\text{l}$ or 15–25 pg injected. The LCW UV–Vis detector shows good linearity. A linear dynamic range from the detection limit up to about 1 mg/l was obtained for the three pesticides, with r^2 values of 0.9986, 0.9993 and 0.9992 for atrazine, diuron and linuron, respectively (slopes 1.01, 1.02 and 1.01).

As an application 1 ml of tap water spiked with the test analytes at the 0.2 $\mu\text{g}/\text{l}$ level was analysed with the LC–LCW detection system. The sample

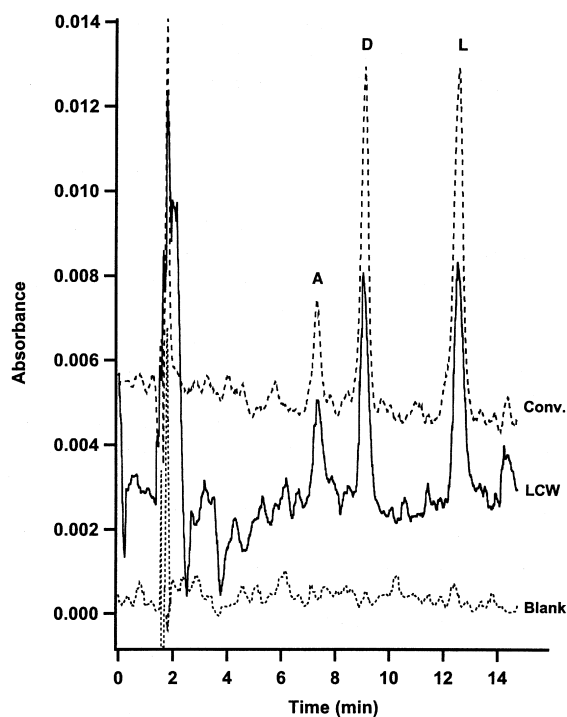

Fig. 2. Reversed-phase LC chromatograms of standard solution of atrazine (A), diuron (D) and linuron (L) in eluent; UV detection at 250 nm; injection volume, 50 μl . Solid line=LCW detection of 1 $\mu\text{g}/\text{l}$ solution; broken line=conventional detection of 50 $\mu\text{g}/\text{l}$ solution; dotted line=LCW detection of blank solution.

was injected directly onto the LC column using the 1 ml loop; i.e., no solid-phase extraction cartridge was used. Fig. 3 shows that, despite a strong baseline disturbance in the 10–11 min range, which was obviously caused by compounds present in the water, the analytes are readily detected. A sample volume of 1 ml appears to be sufficient to reach the 0.1 $\mu\text{g}/\text{l}$ threshold value of the European Union drinking water directive without using analyte preconcentration.

4. Conclusions

Our preliminary study indicates that the use of a 90 cm \times 280 μm I.D. LCW based on the recently developed Teflon-AF 2400 material can be used successfully to improve analyte detectability in conventional-size LC 30- to 50-fold. The detector cell is

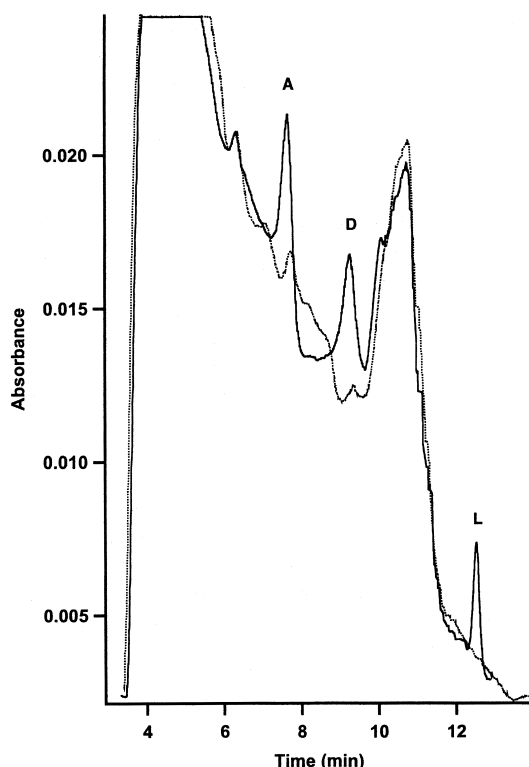

Fig. 3. Reversed-phase LC of Amsterdam tap water spiked with 0.2 $\mu\text{g}/\text{l}$ of atrazine (A), diuron (D) and linuron (L); LCW-type detection at 250 nm, 1 ml injected. The dotted line denotes the chromatogram of the non-spiked water.

rugged and can be installed in standard UV–Vis absorption detectors. The results indicate that present-day monitoring and early-warning studies, which typically require 100-ml samples, can be simplified and that sample loading will become much

less of a bottleneck. Effects of detector cell contamination were not observed during the experiments described; of course, this point has to be explored further.

Amongst the other aspects that will be studied in the near future, one should mention (i) the use of DAD–UV detection and gradient separations, (ii) optimization of the LCW geometry (e.g., testing of 30-cm long waveguides and, if available, smaller-diameter material), and (iii) application to a wider range of analytes and samples. As regards the last aspect, there seem to be no serious limitations as far as applicability is concerned, apart from the wavelength range. Since, in a 90-cm long cell, eluent absorption is 90-fold higher than in a 1-cm cell, the cut-off wavelength will shift to higher values. We therefore expect that 30–90-cm long LCWs will not be applicable in reversed-phase LC at wavelengths beneath about 230 nm.

References

- [1] J. Slobodník, E.R. Brouwer, R.B. Geerdink, W.H. Mulder, H. Lingeman, U.A.Th. Brinkman, *Anal. Chim. Acta* 268 (1992) 55.
- [2] J. Slobodník, M.G.M. Groenewegen, E.R. Brouwer, H. Lingeman, U.A.Th. Brinkman, *J. Chromatogr.* 642 (1993) 259.
- [3] R. Althorn, I. Koev, R.P. van Duyne, M. Litorja, *Appl. Optics* 36 (1997) 8992.
- [4] V. Benoit, M.C. Yappert, *Anal. Chem.* 68 (1996) 183.
- [5] R. Altkorn, I. Koev, A. Gottlieb, *Appl. Spectroscopy* 51 (1997) 1554.
- [6] R.D. Waterbury, W. Rao, R.H. Byrne, *Anal. Chim. Acta* 357 (1997) 99.